

CASE SPECIFICATIONS:

REFRIGERATION  
 LOAD: 9,800 BTU/hr  
 SUCTION TEMP: 20° F  
 LIQUID LINE: 3/8IN ODS  
 SUCTION LINE: 5/8IN ODS

ELECTRICAL 115VAC, 60HZ, 1PH.  
 EVAP. FANS: .26A  
 LIGHT BALLAST: .94A  
 COND. PUMP: 1.0A  
 TOTAL: 2.20A  
 MCA: 15.0A

ELECTRICAL 208/230VAC, 60HZ, 1PH.  
 EVAP. PAN: 7.2A  
 1 1/4HP COND. UNIT: 9.6A  
 TOTAL: 16.8A  
 MCA: 22.1A

BASE HAS CASTERS  
 W/LEVELER LEGS.

CASE HEIGHT WITHOUT  
 OCU NO MORE THAN 82"  
 ROLLING.

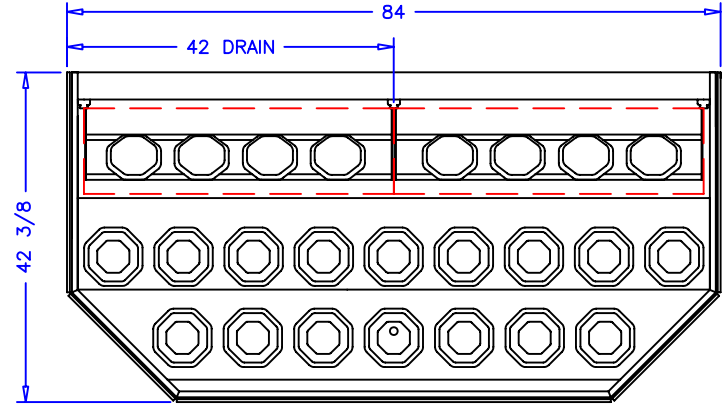

NOTES:

1. OPTIONS NOT SHOWN ON DRAWING SHOULD BE LISTED IN WRITTEN PROPOSAL AND LISTED ON PURCHASE ORDER.
2. ELEC. CONNECTION: 115V/230V, 4x4 SUPPLY BOX AS NEEDED.
3. EXPANSION VALVES: SPORLAN "Q" SERIES STANDARD UNLESS OTHERWISE SPECIFIED.
4. DEFROST CONTROL: REMOTE CASES (N/A, DIGITAL CASE CONTROLLERS AVAILABLE), OPTIONAL CONDENSING UNIT (DIGITAL CASE CONTROLLER).
5. THERMOSTATS & LIQUID LINE SOLENOID VALVES: OPTIONAL.
6. DRAIN: 1 INCH NATIONAL PIPE STRAIGHT THREAD.
7. SPECIFICATIONS SUBJECT TO CHANGE WITHOUT NOTICE.

		 <b>börger systems</b>	
		SCALE: 1:16	DRAWN BY: D HUNT
		DATE: 10-10-08	CHECKED BY:
7FT RFO			
DATE	REV.	Dim: INCH	DRAWING NUMBER
REVISION		TOL:	P5505