

CASE SPECIFICATIONS:

REFRIGERATION:

LOAD: 3,200 BTU/hr
 COIL TEMP: 30°F
 SUCTION STUB: 5/8IN ODS
 LIQUID STUB: 3/8IN ODS

ELECTRICAL 115V, 60HZ, 1PH
 EVAP. FANS: 0.3A
 LIGHTS: 3.6A
 CONDENSATE PUMP: 1.0A
 CONDENSATE PAN: 3.0A
 TOTAL: 7.9A
 MCA: 15.0A

OPTIONAL ELECTRICAL 115V, 60HZ, 1PH
 1/2 HP COND. UNIT: 9.2A
 TOTAL: 9.2A
 MCA: 12.3A

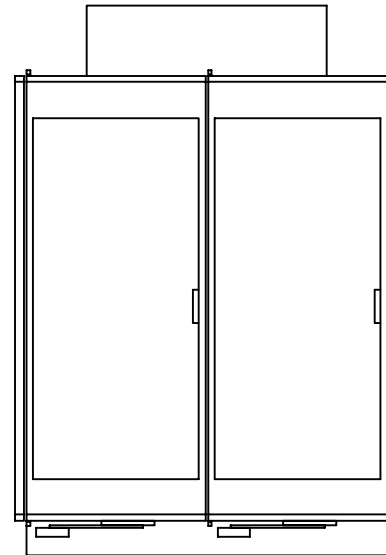
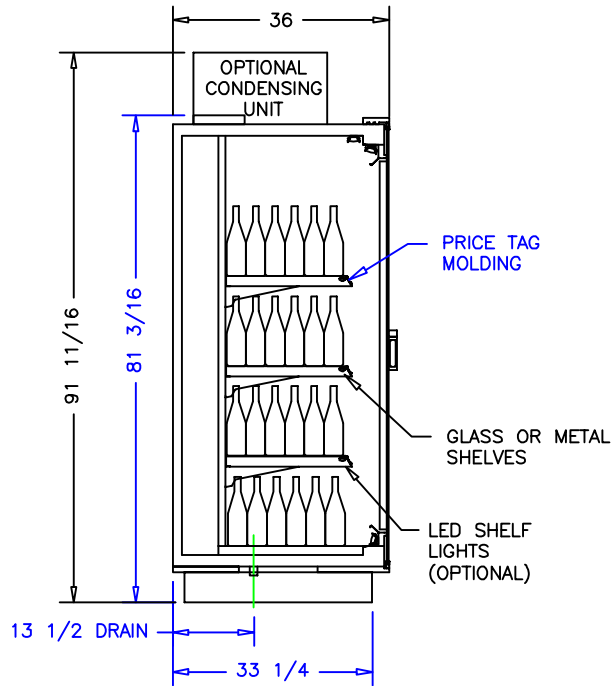
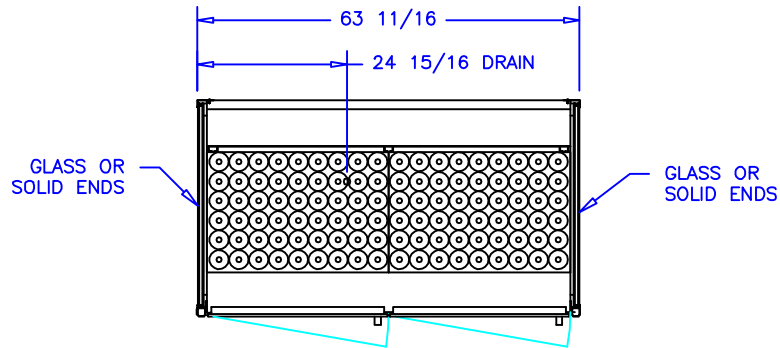

THIS EQUIPMENT IS INTENDED FOR THE STORAGE OF NON-POTENTIALLY-HAZARDOUS BOTTLED OR CANNED PRODUCTS ONLY



NOTES:

1. OPTIONS NOT SHOWN ON DRAWING SHOULD BE LISTED IN WRITTEN PROPOSAL AND LISTED ON PURCHASE ORDER.
2. ELEC. CONNECTION: 115V/230V, 4x4 SUPPLY BOX AS NEEDED.
3. EXPANSION VALVES: SPORLAN "Q" SERIES STANDARD UNLESS OTHERWISE SPECIFIED.
4. DEFROST CONTROL: REMOTE CASES (N/A, DIGITAL CASE CONTROLLERS AVAILABLE), OPTIONAL CONDENSING UNIT (DIGITAL CASE CONTROLLER).
5. THERMOSTATS & LIQUID LINE SOLENOID VALVES: OPTIONAL.
6. DRAIN: 1 1/2 INCH PVC.
7. SPECIFICATIONS SUBJECT TO CHANGE WITHOUT NOTICE.

AUTHORIZATION (PRINT):		DATE:		 börger systems		SCALE: 1:24		DRAWN BY: D HUNT	
						DATE: 4-29-10		CHECKED BY:	
		2-8-18 DRH		2DR WINE					
		2-12-15 DRH							
		DATE		REV.		DIM.		INCH	
		REVISION		TOL:				DRAWING NUMBER	
								P5813	